

Technical guidebook

User guide

Assembling

Maintenance

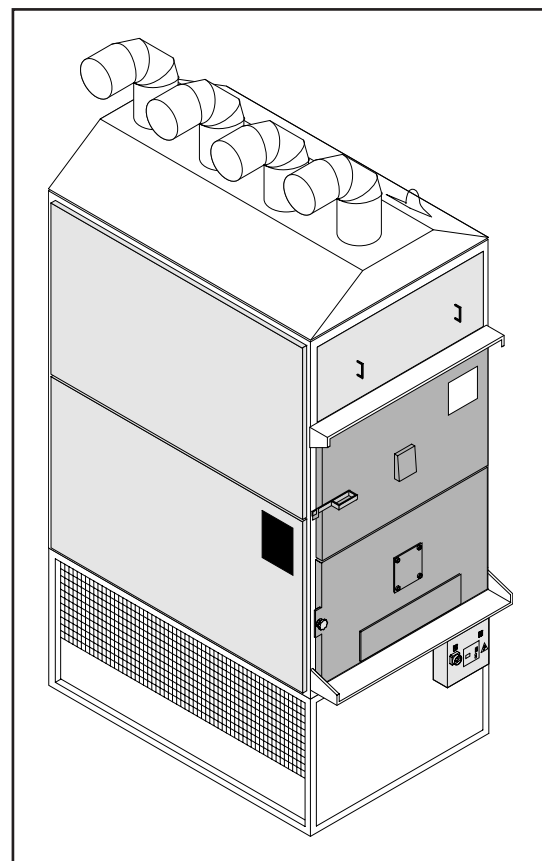

WARM AIR GENERATOR

MOD. F 350

YEAR OF MANUFACTURING

SERIAL NUMBER

Text Version
01-10

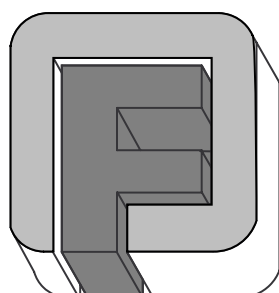

FABBRI TERMOMECCANICA S.r.l.

Via Cangiotti, 10

61100 PESARO (PU)

Tel.0721/282537 Fax 0721/282970

www.fabbriermomeccanica.it

e-mail: info@fabbriermomeccanica.it

LEGEND



This symbol indicates danger, and will be used every time the operator's safety is involved.



This symbol indicates caution and is used to draw attention on very important operations needed for the proper and long-lasting use of the.



This symbol represents an environmental note, and draws attention on rules to follow for the environment's preservation.

Dear Customer,

Before using the machine, it is important to read this handbook.

In order to ensure the operator's safety, the machine's devices must be kept in constant efficiency.

This booklet shows how to use and maintain the machine, and it is the operator's duty and responsibility to follow the present instructions.



WARNING! The following instructions are meant for your safety.

Keep this booklet with care, for other operator's easy use.

The installation must be performed according to the manufacturer's instructions by trained personnel.



This machine must only be used for the purpose it has been built. Any other use is to be considered dangerous.

The machine must be used only by specifically trained personnel.

For any repair operations, always refer to a manufacturer-authorized assistance centre, and ask for original spare parts.

Disregarding any of the above might compromise the machine's safety.

MODEL

SERIAL NUMBER

YEAR OF MANUFACTURING

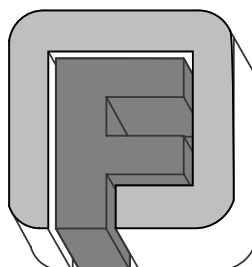

FABBRI TERMOMECCANICA S.r.l.

Via Cangiotti, 10

61100 PESARO

Tel.0721/282537 Fax 0721/282970

www.fabbriermomeccanica.it

e-mail: info@fabbriermomeccanica.it

INDEX

1 TECHNICAL SPECIFICATIONS.....	5
1.1 MACHINE DESCRIPTION	5
1.2 APPLIED REGULATIONS	5
1.3 WORK STATION	6
1.4 PROTECTIONS.....	6
1.5 MODELS	7
1.6 IDENTIFICATION	7
1.7 ENCUMBRANCE	8
1.8 LABELLING	8
1.9 TECHNICAL SPECIFICATIONS	9
2 INSTALLATION	10
2.1 TRANSPORT.....	11
2.2 LIFTING AND HANDLING.....	11
2.3 ACCESSORIES	11
2.4 ENVIRONMENTAL SPECIFICATIONS	12
2.5 INSTALLATION	13
2.6 MAINTENANCE SPACE	13
2.7 ELECTRIC PLUG-IN.....	14
3 OPERATION.....	15
3.1 PRELIMINARY CONTROLS.....	15
3.2 STARTUP.....	16
3.2.1 TWIN THERMOSTAT FUNCTIONING	16
3.2.1.1 FAN FUNCTIONING.....	16
3.2.1.2 LIMIT FUNCTIONING	16
3.2.1.3 PLUGGING AND CALIBRATION	16
3.3 OPERATION.....	17
3.4 REGULAR STOP	17
4 ORDINARY MAINTENANCE.....	18
4.1 PRELIMINARY CONTROLS.....	18
4.2 CLEANING THE WARM AIR GENERATOR.....	18
4.2.1 WIPING OFF THE ASH.....	18
4.2.2 CLEANING THE FLUE.....	18
4.2.3 CLEANING THE HEAT EXCHANGER.....	19
4.3 FANBELT STRETCHING.....	19
5 END OF SERVICE	20
6 ACOUSTIC POLLUTION.....	20
7 SPARE PARTS CATALOGUE.....	21
TAV. 1 SPARE PARTS	22
TAV. 2 ELECTRIC PLAN F350-1	23
TAV. 3 ELECTRIC PLAN F350-2.....	24

1 TECHNICAL SPECIFICATIONS

1.1 MACHINE DESCRIPTION

This machine is a warm air generator which operates with solid fuel.

The framework is made up of a square profiled steel chassis and panels in galvanized polished steel.

On the chassis' lower part are located the vents for the air to be heated, which push the air inside the heat exchanger. The air is then expelled by exhaustion vents on the upper part of the machine.

The combustion chamber is chrome INOX steel, reinforced with ribs, and it is placed above the vents.

Inside, the furnace is separated from the cinerary by a steel grid.

The loading doors on the back of the machine are steel and internally coated in refractory materials. On the lower door you will find the shutter for regulating the combustion chamber's power.

The upper door, with a handle, is used to load fuel in the machine.

The fumes' exhaust pipe in the combustion chamber is linked to the heat exchanger above it.

The heat exchanger is made up of a series of pipes that run down the back and are linked to the draft mechanism, which is in turn operated by an external engine.

On the control panel you will find the switches to start up the draft engine and the air heating vents.

1.2 APPLIED REGULATIONS

Summary of laws and harmonized and technical rules

1.	Directive 2006/42/CE (Directive regarding Machines).
EN 292/1	Machine safety – fundamentals, general design principles – terminology, basic methodology.
EN 292/2	Machine safety – fundamentals, general design principles – technical specifications and principles.
EN 294	Machine safety – safety distance to avoid upper arms to make contact with dangerous parts - 1992.

EN 563 Machine safety – contact surface temperature. Ergonomic data to establish temperature values limits for heated surfaces. (june 1994).

UNI 8364 Heating systems – checkup and maintenance.

2. Directive 06/95/CE (Directive regarding low tension).

EN 60204-1 Machine safety – electric equipment Part 1 general requirements. - 1992 (revision of EN 60204-1).

EN 60529 Casing protection degrees (june 1991)

EN 60445 Identification of terminals and drawn conductors, and rules for the alphanumeric

3. Directive 04/108/CE (Directive regarding EMC - electromagnetic compatibility).

EN 50081-2 Electromagnetic compatibility – generic emission rule. Part 2: industrial environment

EN 50082-2 Electromagnetic compatibility – generic immunity rule. Part 2: industrial environment.

1.3 WORK STATION

The machine need not be manned, therefore there is no need for an operator to use it, just to periodically reload fuel.

The operator's presence is required only when combustion is started.

1.4 PROTECTIONS

The machine is equipped with the following safety systems (Fig.1):

- Protection of the power grid with doorlock (pos.A).
- Mechanical protection in the loading area, coated in refractory materials (pos.B).
- Permanent mechanical protection using a galvanized steel sheet on the machine's sides (pos.C).
- Mechanical protection using a metal grid in the vents' suction tract (pos.D).
- Mechanical protection using a steel sheet reinforced with refractory materials in the heat exchanger's inspection tract (pos.E).
- Alarm (pos.F).

Furthermore, for the operator's safety we recommend:

- Protective suits.
- Shockproof shoes.
- Protective gloves.

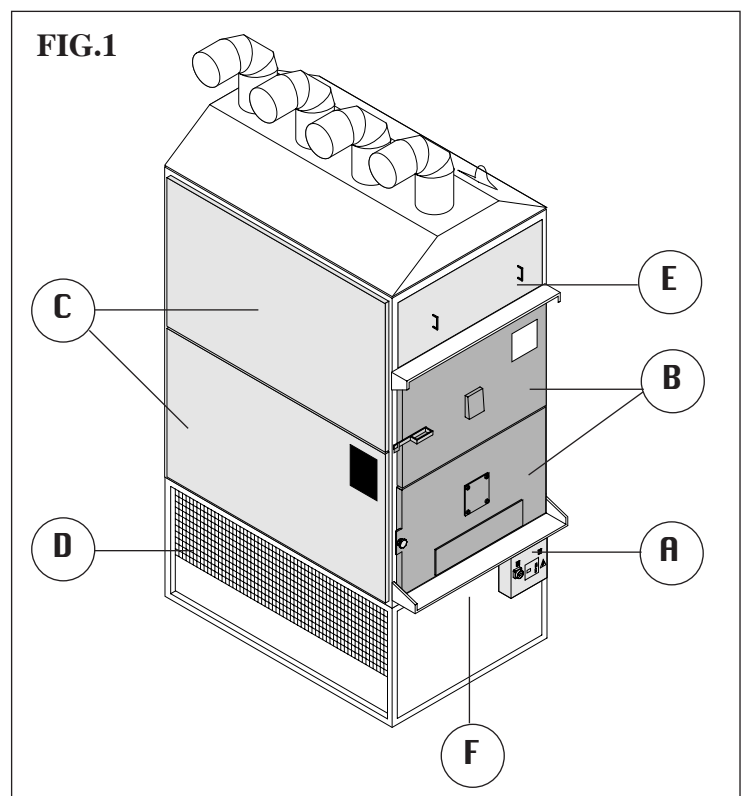
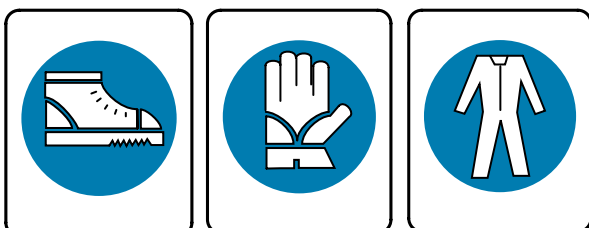

1.5 MODELS

FIG.2

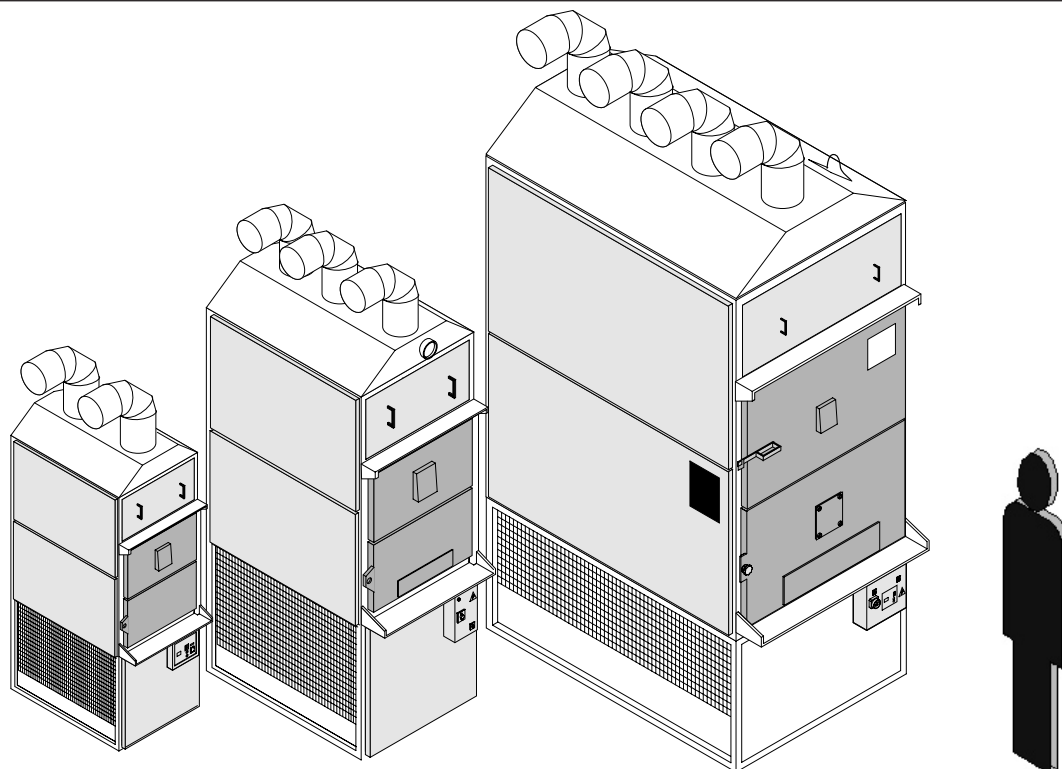

MOD. F28
MOD. F55 S.V.
MOD. F55 C.V.
MOD. F85 S.V.
MOD. F85 C.V.

MOD. F120
MOD. F240

MOD. F350

1.6 IDENTIFICATION

When contacting the manufacturer, always provide the machine's serial number and year of manufacturing, found on the plate affixed on the right hand side (see fig.3).

FIG.3

FABBRI		
TERMOMECCANICA S.r.l		
Via Cangiotti, 10 - 61100 - Pesaro - Italia Tel. 0721.282537 - FAX 0721.282970		
GENERATORE DI ARIA CALDA		
APPARECCHIO TIPO	_____	
ANNO DI COSTRUZIONE	_____	
NUMERO DI SERIE	_____	
POT.MASS. FOC.	KW	KCa/h
POT.TERMICA RESA	KW	KCa/h
TENSIONE	V	
POT.ELETTRICA	KW	
PORT. ARIA	m ³ /h	
COMBUSTIBILE	LEGNA	
PESO	kg	

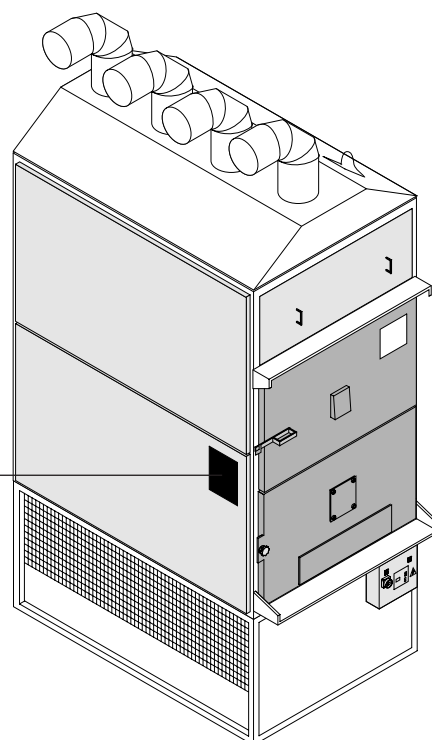

1.7 ENCUMBRANCE AND WEIGHT

FIG.4

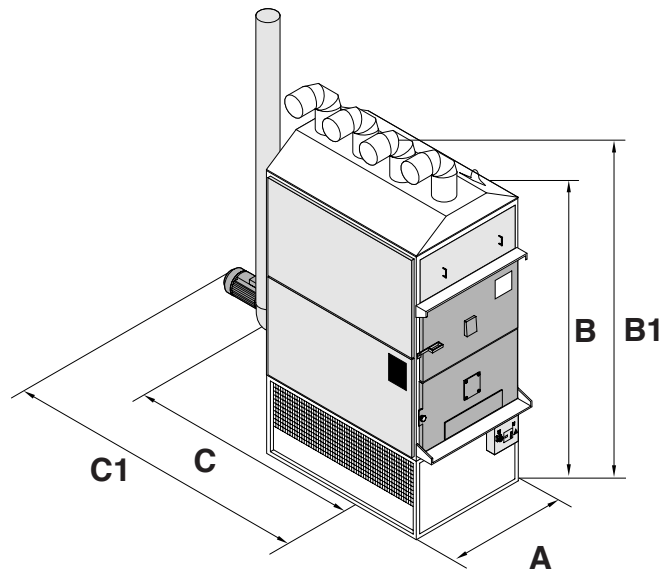





MODELS	F28	F55 S.V.	F55 C.V.	F85 S.V.	F85 C.V.	F120	F240	F350
A (mm)	560	690	690	800	820	930	1100	1220
B (mm)	1560	1750	1750	1980	1980	2200	2500	3000
B1 (mm)	1900	2100	2100	2400	2400	2600	3000	3400
C (mm)	920	1150	1150	1280	1280	1700	1900	2700
C1 (mm)	920	1150	1520	1280	1690	2060	2290	3160
WEIGHT (kg)	170	260	305	365	415	615	850	1575

1.8 LABELLING

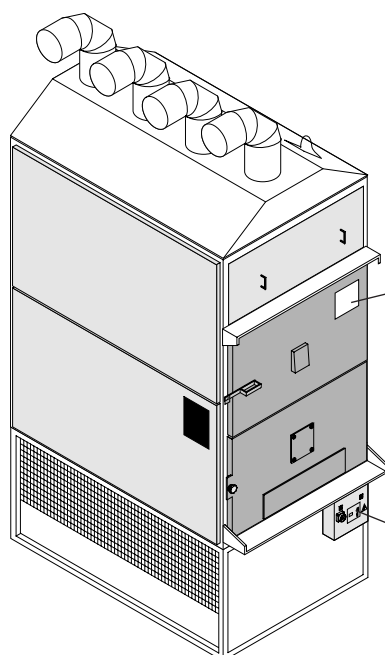
The machine features warning labels in the indicated areas (fig.5).

FIG.5



AVVERTENZE	WARNING	HINWEIS
1) PRIMA DI ACCENDERE IL FUCO ASSICURARSI CHE LE VENTOLE GIGINO PER IL VERSO GIUSTO. 2) PER UNA BUONA GESTIONE DEL GENERATORE USARE TUTTI I BERMESSE DALLA LEGGE. 3) CARICARE MODERATAMENTE: PERCHÉ UN CORRENTE POTREBBE FONDERE IL DILATARME IL FORNO. 4) AL TERMINE DI OGNI STAGIONE DI RISCALDAMENTO EFFETTUARE UNA PULIZIA GENERALE DEL GENERATORE. 5) NON UTILIZZARE COMBUSTIBILI IN POLVERE O SEGATURA DI LEGNO.	1) BEFORE LIGHTING THE FIRE THE THERMOSTAT WORKS. FOR A GOOD RUNNING OF THE GENERATOR USE ALL THE SOLID COMBUSTIBLES ALLOWED BY LAW. LOAD WITH MODERATION: A BLACK-OUT OF POWER CUT COULD MELT THE THERMOSTAT AND DILATE THE OVEN. AT THE END OF EACH HEATING SEASON UNDERTAKE A GENERAL CLEANING OF THE GENERATOR. 5) DO NOT USE POWDER OR SAWDUST.	1) VOR DEM ANZÜNDEN DES FEIERS SICH VERGEWISSEN, DASS DIE LÜFTERRÄDER IM RICHTIGEN SINN DREHEN IM DER THERMOSTAT. FÜR EIN GUTES FUNKTIONIEREN DES GENERATORS JEGLICHEN VOM GESETZ ERLAUBTEN BRENNSTOFF VERWENDEN. 3) GEMÄßT AUFLADEN, DENN EIN STOMAUSFALL KÖNNANTE DEN THERMOSTAT SCHMELZEN UND DEN OFEN DEHNEN. AM ENDE JEDER HEIZPERIODE EINE GENERELLE REINIGUNG DES GENERATORS DURCHFÜHREN. 5) KEINE BRENNSTAUB ODER HOLZMEHL VERWENDEN.
		
ATTENZIONE SUPERFICIE TEMPERATURE ELEVATE	ATTENTION HIGH SURFACE TEMPERATURES	ACHTUNG HEIßE OBERFLÄCHE

1.9 TECHNICAL SPECIFICATIONS

MODELS		F28	F55	F85	F120	F240	F350
DATA							
Fuel		WOOD - CHIPPINGS – TURF					
Furnace power	(Kcal/h)	29900	69000	99500	150000	300000	437000
	(KW)	34	80	115	175	350	510
Effective conventional power	(Kcal/h)	25000	55000	80000	120000	240000	350000
	(KW)	29	64	93	140	279	407
Air intake (m³ /h)		2200	3500	6300	8900	17800	26000
Fuel consumption (Kg/h)		13	20	30	43	85	125
Vents electric power (HP)		0,2	0,35	1,5	3	4	6
Suction vents electric power (HP)		-	0,35	0,35	0,75	0,75	1,5
Engine voltage (V)		220 (monoph.)	220 (monoph.)	380 (triph.)	380 (triph.)	380 (triph.)	380 (triph.)
Chimney diameter (mm) (models without fumes vent)		160 Ø	180 Ø	180 Ø	-----	-----	-----
Chimney diameter (mm) (models with fumes vent)		-----	180 Ø	180 Ø	200 Ø	200 Ø	250 Ø
Exhaust pipes diameter (mm)		2x180Ø	2x200Ø	2x250Ø	3x250Ø	3x300Ø	4x350Ø

2 INSTALLATION



WARNING!

The generator's installation must be performed in observation of the current laws and technical rules, and its design must be performed by a freelance professional with regular profession registration.

HEATING SYSTEM DESIGN AND INSTALLATION

Law n. 46, 5th May 1990,
“Rules for systems safety”.

Law n.10, 9th January 1991,
“Rules for enforcing the national energetic plan regarding energy rationing, energy saving, and development of renewable energy sources”.

Presidential Decree n. 447, 6th December 1991,
“Rules for applying the Law n. 46, 5th May 1990, regarding systems safety.”

Presidential Decree n.412, 26th August 1993,
“Rules for designing, installing, operating and maintaining heating systems in buildings towards the lowering of consumptions in respect of art. 4, paragraph 4 of the Law n.10, 9th January 1991.”

RULES FOR PREVENTING POLLUTION DURING HEATING SYSTEM INSTALLATION.

Law n. 615, 13th July 1966
“Rules against pollution”.

Presidential Decree n. 1391, 22nd December 1970
“Rules for applying Law n. 615, 13th July 1966 with rules to prevent pollution, regarding heating systems”.

RULES FOR PREVENTING FIRES DURING HEATING SYSTEM INSTALLATION.

Minister of Internal Affairs Draft n.73, 29th July 1971
“Heating systems operating with oil fuel or oil gas – Rules against pollution. Rules to prevent fires.”

Presidential Decree n.689, 26th May 1959
“Indication of companies and operations subject to controls by the Firefighters Command in order to prevent fires.”

Ministerial Decree 16th February 1982
“Changes to Ministerial Decree 27th September 1965, dealing with companies subject to controls to prevent fires.”

Decree n.246, 16th May 1987
“Rules for fire prevention in civilian buildings.”

INSTALLATION RULES FOR THE ELECTRIC SYSTEM'S SAFETY.

Law n. 186, 1st March 1968

“Rules for producing and installing electrical and electronic systems, materials, and machines.”

Italian Electro-technical Committee Rule 64-8

Electric systems operating at a nominal tension non above 1000 V A/C and 1500 V D/C.

2.1 TRANSPORT

The machine can be transported via truck, ship, train, and plane.

The machine is shipped without special packaging, and it is built to be disassembled in two parts: the ventilators group and the combustion chamber-heat exchanger group. All accessories are shipped separately.

2.2 LIFTING AND HANDLING

Those groups can be individually lifted with a crane or freight elevator, using two hooked tows at least 1 meter long.

Lifting the ventilators group

Put firmly in place the hook end of the tows on top of the part, and through the eyebolts on its lower part using the appropriate clasps (fig. 6).

Place the hook end of the tows on top, and in the eyebolt in the lower part (fig. 6), placed in the plates welded on the exchanger.

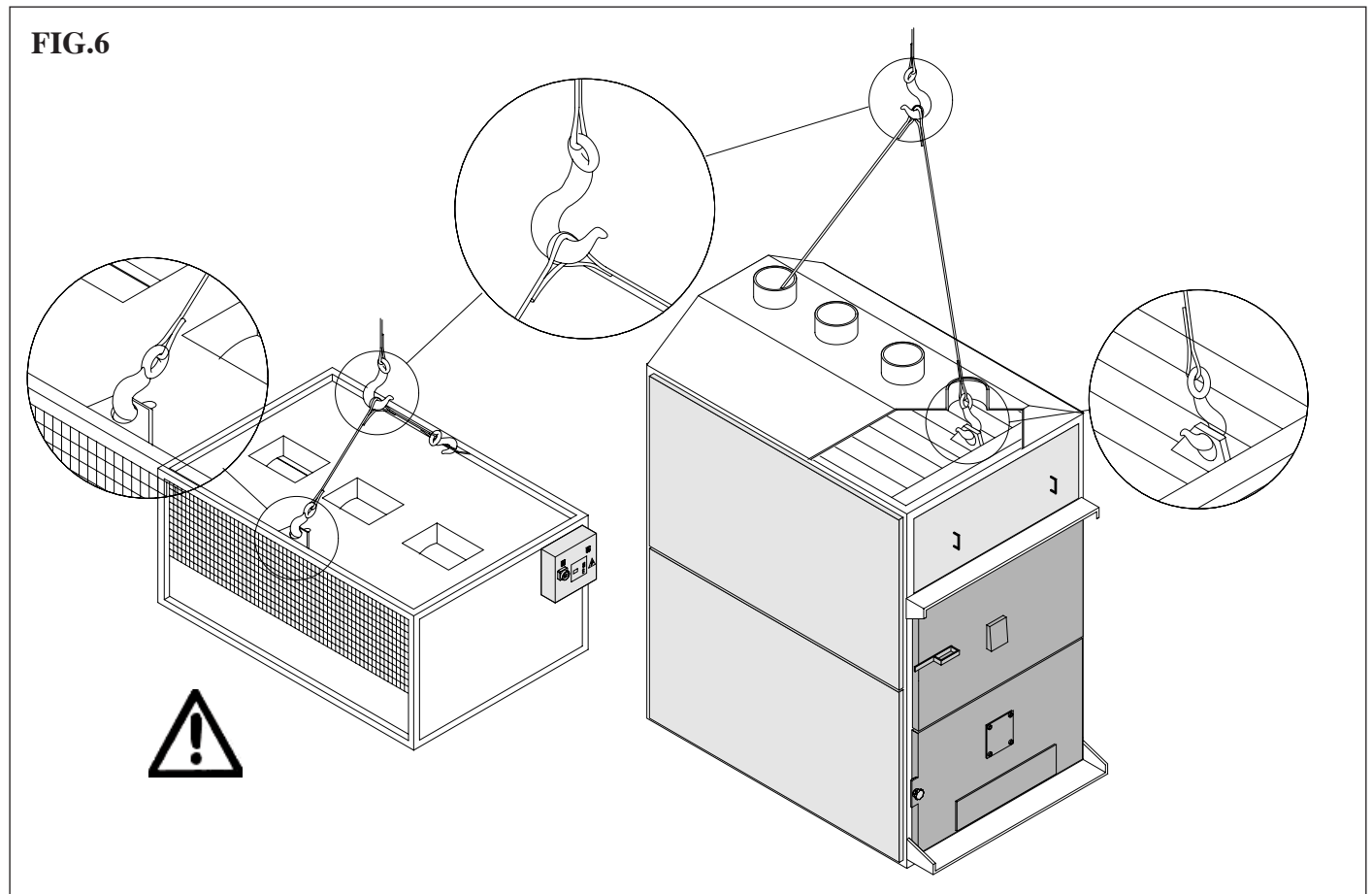

Lifting the combustion chamber-heat exchanger group

Put firmly in place the hook end of the tows on top of the group, and through the eyebolts placed on the exchanger's welded plates (Fig. 6).



WARNING!

Lifting the machine with shorter tows can damage its upper parts.

2.3 ACCESSORIES

The only accessory for the machine is the fumes purifier, available on demand.

2.4 ENVIRONMENTAL SPECIFICATIONS

While positioning the machine, keep in mind that its functioning is guaranteed under an ambient temperature between 5°C and 40°C, and relative humidity between 35% and 75%.

2.5 INSTALLATION



- Package

Do not throw the package in the trash, instead separate the various components according to materials (cardboard, wood, steel, polyester, and so on) and dispose of them according to your Country's laws.

The machine needs a solid support on the floor. The ventilators group must be positioned first (pos. 1 fig. 7). The guiding squares must be installed on the group's chassis four corners (pos. A fig. 7). Afterwards, place the combustion chamber-heat exchanger group upon the ventilators group (pos. 2 fig. 7). Next, install the casing with the heated air output (pos. 3 fig. 7).

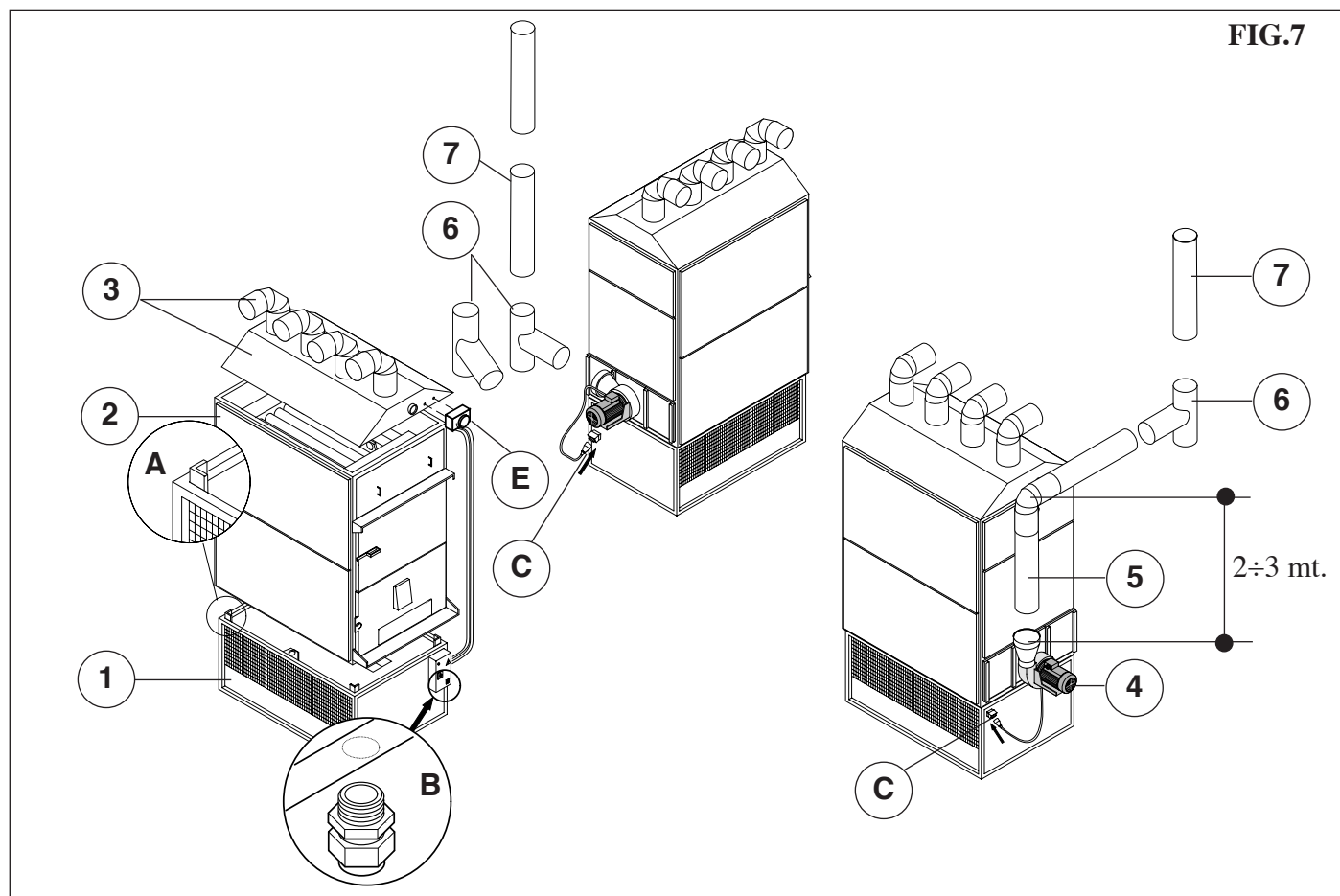
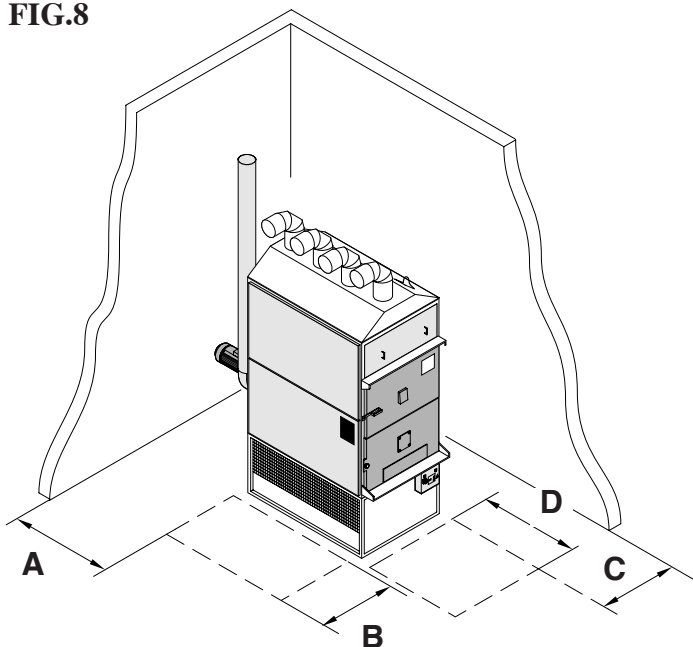

FIG.8



	A	B	C	D
F28	1000	600	600	1500
F55	1000	600	600	1500
F85	1000	600	600	1500
F120	1200	600	600	1800
F240	1200	600	600	1800
F350	1200	600	600	2000



The values in the table are expressed in mm.

Finally, install the fumes suction group (pos. 4 fig. 7), and the various segments of the warm air generator's flue (pos.5, 6, 7 di fig.7).



WARNING!

You must install at least one special pipe T-shaped element in the flue (pos.7 fig 7a-7b), which helps in cleaning operations.



WARNING!

The initial vertical section of the flue should never measure more than 2 or 3 meters in length (pos. 5 fig.7a-7b) before applying the T-shaped tract (pos.7 fig 7a-7b).

2.6 MAINTENANCE SPACE

During installation of the machine, it is advisable to set up an area for later maintenance operations, as indicated in fig. 8.



IMPORTANT: the values in the tables are the recommended minimum values.

2.7 ELECTRIC PLUG-IN



WARNING!

Before plugging in, make sure you have a proper grounding system which follows the current European Laws (EN).

Check the compatibility of the network voltage with the specificatins in the appropriate label in the machine (fig. 2).

Power fluctuations greater than $\pm 10\%$ of the nominal voltage indicated in the label can cause serious damage on the machine. That damage in not covered by the warranty.



IMPORTANT: verify that the power cable is the right size.

Turn the switch on the 0 position (pos. A fig.11).

Insert the machine's power cable through the gland under the power grid (pos. B fig.7). Connect wires in the terminal by following the attached electric plan and following (TAV. 2).

After that, plug the fumes suction group with the power connector (pos. C fig. 7).

Once the cable has been plugged, the suction vents' orientation should be checked.

Please proceed as follows:

- Turn on the general switch:

Press the "FAN" button to start up the vents (fig.10).

Make sure the vents' orientation in correct (refer to the arrows on the fans).



WARNING!

Should this checkup be skipped, the combustion chamber could be damaged during the first startup, due to overheating of the entire machine.

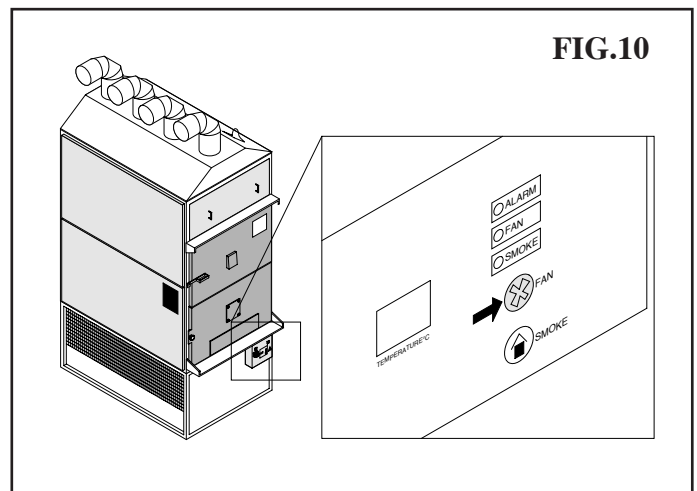

3 OPERATION

For F85 SV models

3.1 PRELIMINARY CONTROLS



WARNING! Before starting up the machine make sure that:

- The power grid's general switch is turned off (pos. OFF).
- The machine's general switch is turned on 0 (pos. A fig. 11).
- All installation and assembling has been performed correctly, especially during orientation of the vents.

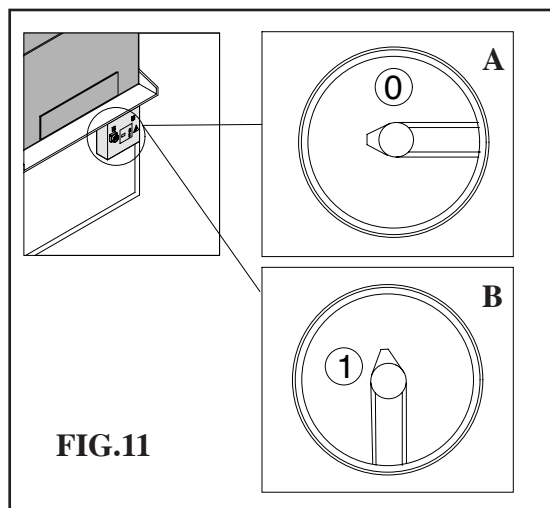

3.1.1 CONTROLS IN THE ELECTRONIC PANEL

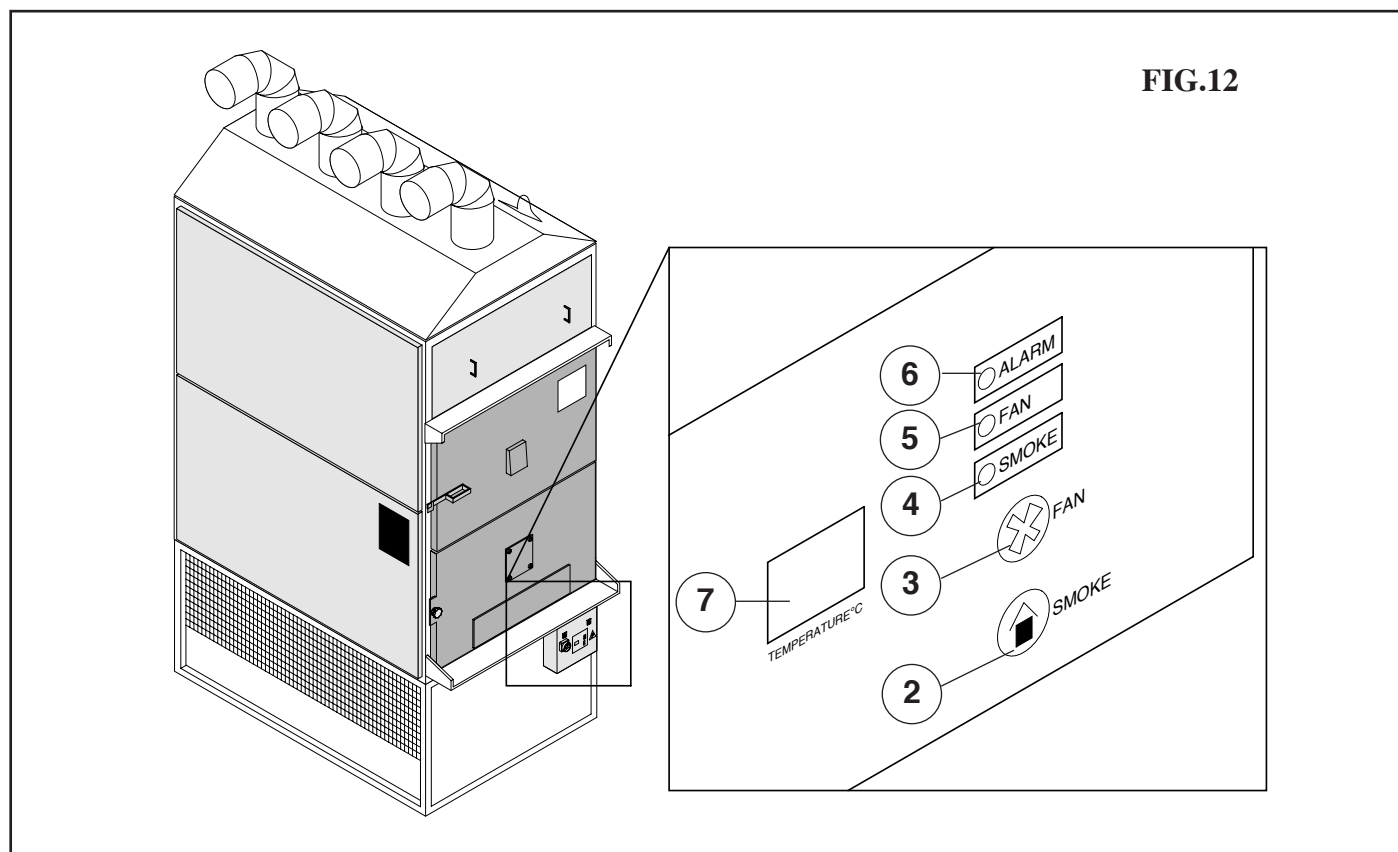

- 2) fumes vent button;
- 3) air vent button;
- 4) fumes vent light (green);
- 5) air vent light (green);
- 6) alarm light (red);
- 7) temperature display.

3.2 STARTUP

Turn on the machine's general switch (pos.B fig.11).
Load the fuel in the grid's upper part.
Turn on fuel loading and wait for combustion to start up.



WARNING!
Do not use liquid fuel.



WARNING!
If the machine has got a fumes vent, do not turn it off during combustion.

To adjust combustion, regulate suction power in the lower door (pos.3 in fig.13).

When temperature reaches 45°C, the air vents will activate automatically (pos.5 in fig.12), and they will automatically switch off as well when temperature drops below 41°C.

The alarm's thermostat is already set to activate at 90°C.

3.2 STARTUP (summer)



IMPORTANT: to turn on cold air circulation, press the vent button (pos.3 fig.12) in absence of combustion.

3.3 OPERATION

The machine must only be loaded with fuel via the upper door (pos. 1 in fig.13). Fuel examples include:



- Dry wood not treated with chemicals.
- Wood chippings pressed in bundles.



WARNING! Do not use powdered wood, nor liquid fuel, during startup and combustion.

Removing ashes.

Remove ashes only after combustion has ceased, and only after temperature has dropped below 40°C, then:

- open up the two front doors (pos. 1 and 2 in fig.13).

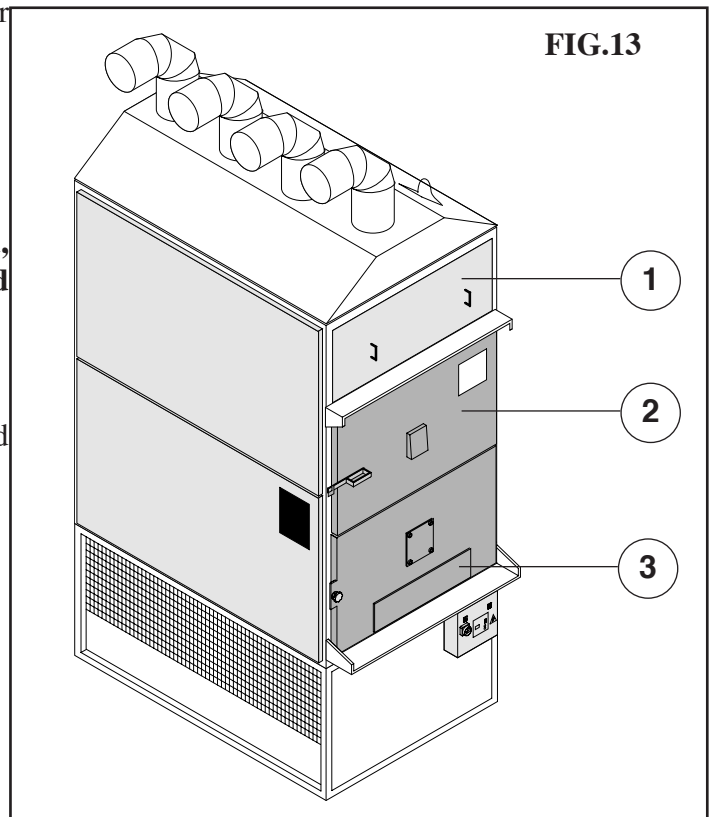



IMPORTANT: the lower door will not open if the upper door is open.
The lower door is closed with a knobbed screw.

- Empty the cinerary.
- Close the doors.



IMPORTANT: do not place the ashes near the vents' suction area (fig. 14).



WARNING! Do not overload the machine. An excessive heat generated by combustion could deform the machine's structure.

When the warm air generator is on, there is a chance that the alarm will be set off. This is due to the excessive heat generated by the furnace. In this case, lower the heat generation by shutting down the air suction (pos. 3 in fig. 13), and stop loading fuel.

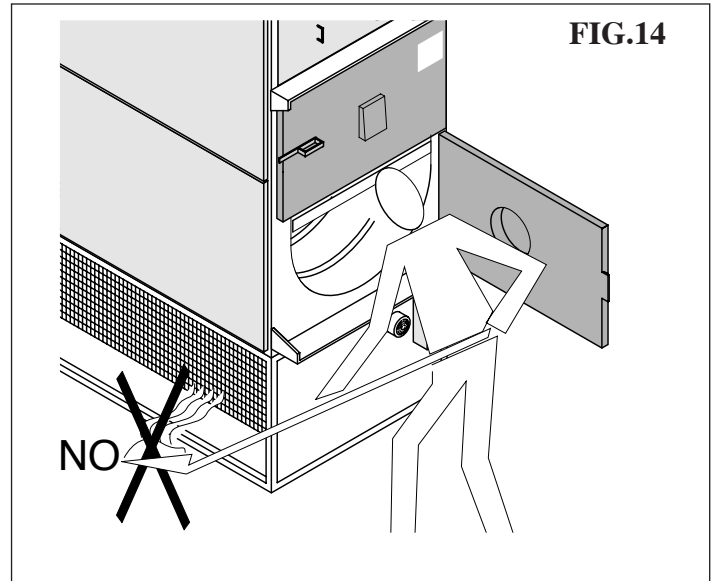

3.4 REGULAR STOP

You can turn off the furnace by shutting down the air suction (pos. 3 in fig. 13)

Then, after the machine has cooled down, switch off the flue's suction and the vents (pos. 0 in fig. 12), and finally turn off the machine's general switch (pos. A in fig. 11).



WARNING!

Do not turn off the general switch before combustion has ceased and the ashes are cold.

4 ORDINARY MAINTENANCE

4.1 PRELIMINARY CONTROLS



WARNING! Before maintenance, make sure that:

- The power grid's general switch is turned off (pos. OFF)
- The machine's general switch in on 0 (Fig. 15), that a padlock is placed on the appropriate lock, and its keys given to the safety operator
- Make sure the machine is not powered during maintenance operations

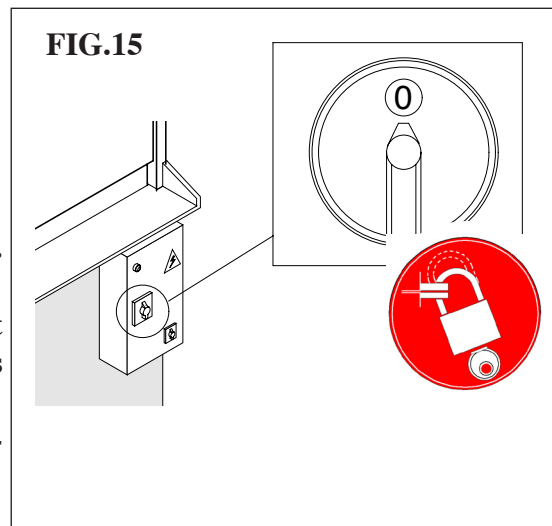

4.2 CLEANING THE WARM AIR GENERATOR



IMPORTANT: at season's end, clean the combustion chamber, the flue, and the heat exchanger's pipes.

4.2.1 WIPING OFF THE ASH

Every time the machine is stopped, the ash on the bottom of the combustion chamber must be removed.

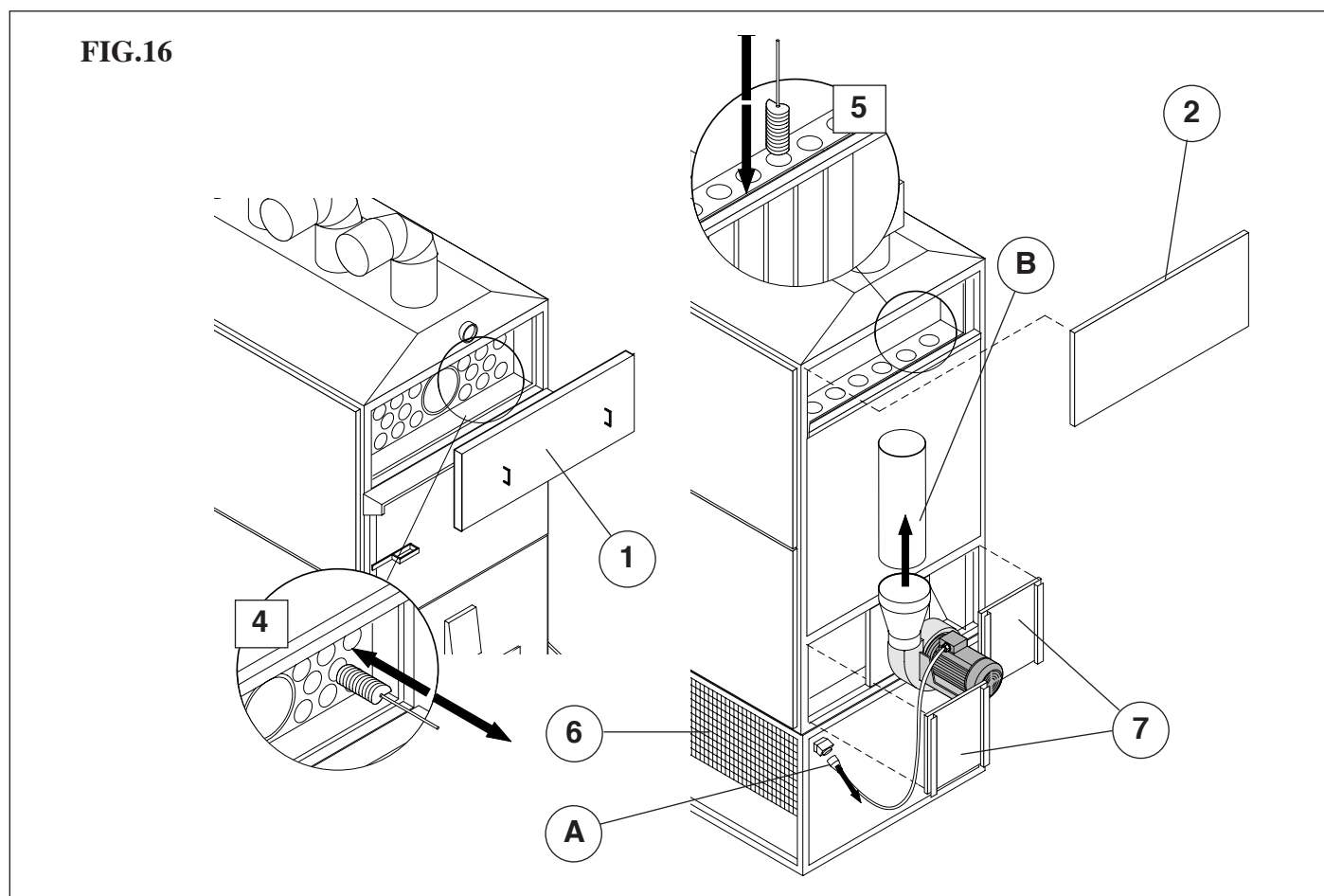

4.2.2 CLEANING THE FLUE

To proceed with cleaning you must:

- Unplug suction (pos. A in fig. 16).
- Unplug the flue from the suction (pos. B in fig. 16).
- Remove soot from the flue with an iron brush.
- Reassemble flue with suction.
- Plug suction.

4.2.3 CLEANING THE HEAT EXCHANGER

To proceed with cleaning you must:

- remove back protection panel (1 in fig. 16) by unscrewing it.
- unplug suction (pos. A in fig.16).
- remove the rest of the back protection panels by unscrewing them (pos.2, 7 fig.16).
- clean the exchanger's pipes with a helix iron brush, from the front of the machine (pos. 4 in fig.16).
- do the same for the descending vertical pipes (pos.5 fig.16).
- install back the protection panels (part. 1,2 and 7 fig.16).
- plug suction (pos.A fig.16).
- plug flue with suction.

4.3 FANBELT STRETCHING

You should periodically stretch the fan belts.

To access the fan belts, remove the protection grids (pos. 6 fig. 16).

- Regulate the fan belts' stretching with the registry screw (fig. 17).
- In case this doesn't work, replace the belt.
- At operations complete, replace the protection grid.

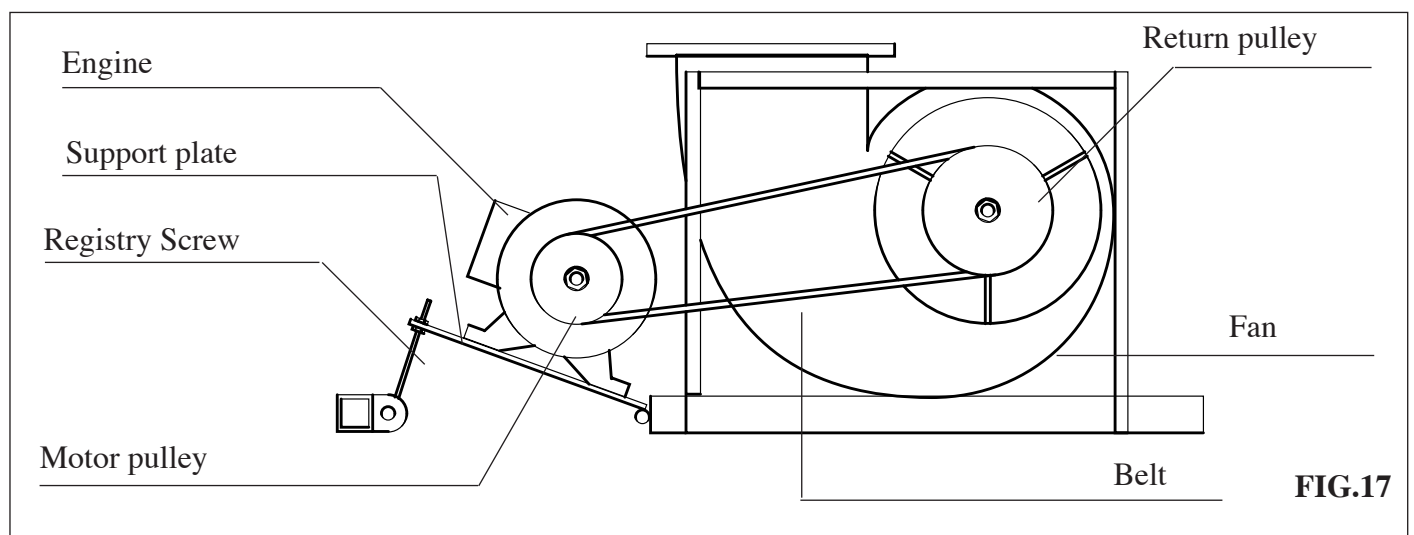

4.3.1 REPLACING THE THERMOSTAT PROBE

To replace the thermostat probe:

- unscrew the probe holder (pos.A fig.18);
- remove the probe holder and remove the central screw (pos.B fig.18) in the probe's lodge;
- unplug the probe's lodge by unscrewing it (pos.C and pos.D fig.18).

FIG.18

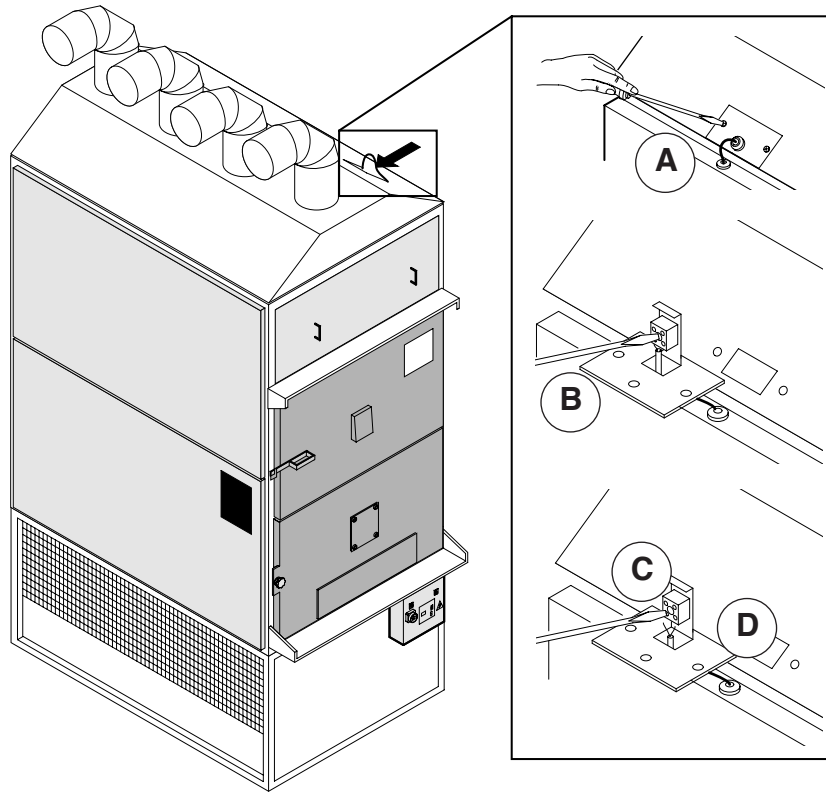

4.3.2 REPLACING THE FUSE

The fuse lies inside the electronic panel. To replace it, consult the electric plans (tav.2-tav.3).

5 END OF SERVICE



When the machine's lifetime is up, you should:

- remove all rubber parts (O-ring, gaskets, girds, etc...).
- remove all recyclable plastic components (thermoplastic parts) and separate them. from the unrecyclable ones (thermo-resistant parts).
- remove all copper parts (cables).

Dispose of the different materials according to your Country's laws.

6 ACOUSTIC POLLUTION



The sound emission levels for the model F350 have been tested according to the ISO 11202 rules, and the following maximum sound thresholds have been recorded:

MODELS	L _{pA} (dB(A))		
	F 350	-----	-----
Machine with only fumes vent turned on	< 70	-----	-----
Machine with only warm air vent turned on	74,9	-----	-----
Machine with both vents turned on	75,0	-----	-----

L_{pA}: Max sound pressure level recorded on the operator's work station

7 SPARE PARTS CATALOGUE

HOW TO ORDER SPARE PARTS

To order spare parts, the following specifications must be presented:

- Machine type (model, serial number, year of manufacturing).
- Spare part description.
- Quantity needed.
- Any indications the spare part might have engraved on a plate.

N°	DESCRIZIONE	N°	DESCRIPTION	N°	BEZEICHNUNG
1	SONDA TEMPERATURA ARIA	1	AIR TEMPERATURE SENSOR	1	TEMPERATURFÜHLER
4	QUADRO ELETTRICO	4	ELECTRIC CONTROL PANEL	4	SCHALTAFEL
5	GRIGLIA DI APPOGGIO SCAR- TI	5	REJECTED MATERIALSUPPORT GRILLE	5	GITTER ABFALLABLAGE
6	SPORTELLLO DI CONTROLLO ESTRAZIONE CENERI	6	ASH EXTRACTION CONTROL PANEL	6	KONTROLLTÜR ASCHEENT- NAHME
7	SPORTELLLO CARICAMENTO MANUALE	7	MANUAL LOADING PANEL	7	TÜR ZUM MANUELLEN BELA- DEN
8	SPORTELLLO PULIZIA TUBI	8	PIPE CLEANING PANEL	8	TÜR ZUR ROHRREINIGUNG
9	BOCCHHE DI MANDATA ARIA CALDA	9	HOT AIR OUTLET OPENINGS	9	ZULUFTSTUTZEN WARME LUFT
10	GRATA DI ASPIRAZIONE	10	SUCTION GRATING	10	SAUGGITTER
11	GRUPPO DI ASPIRAZIONE ARIA	11	AIR SUCTION ASSEMBLY	11	BAUGRUPPE LUFTANSAU- GUNG
12	GRUPPO DIASPIRAZIONE FUMI E SPORTELLLO PER CENERE	12	SMOKE SUCTION ASSEMBLY AND ASH PANEL	12	BAUGRUPPE DAMPFABSAU- GUNG UND ASCHETÜR

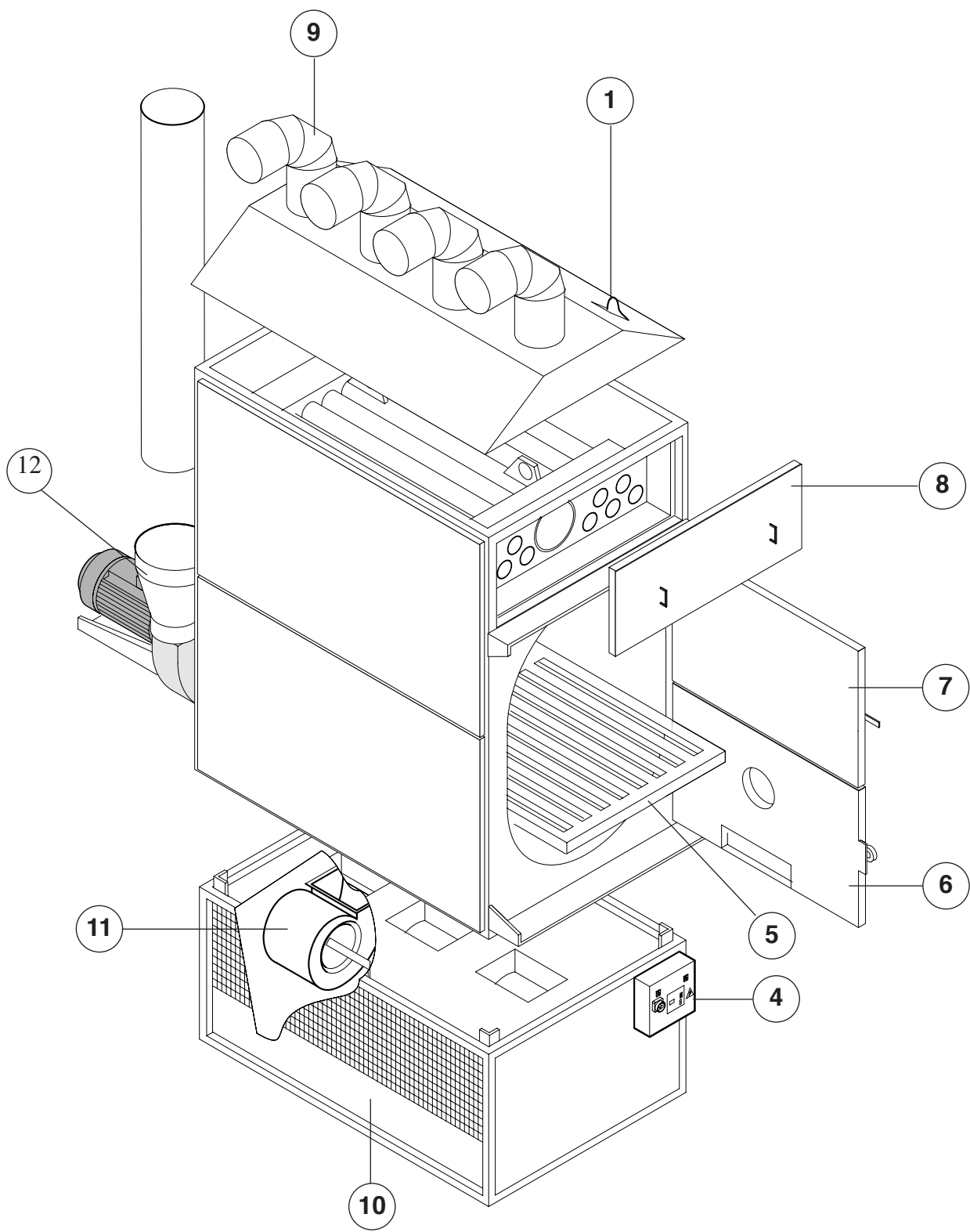



STANDARD F350 SHEET 1 - 2 -

DEFINIZIONI

- Ib - Actual applied current (device absorption)
- In - Nominal current
- Ir - Regulated current
- Pn - Nominal active power
- Vn - Nominal voltage (of the appliance)

LEGENDA

- I - Distribution switches
- RT - Temperature relays
- T - Thermostat contact
- M - Motors
- C - Contactors

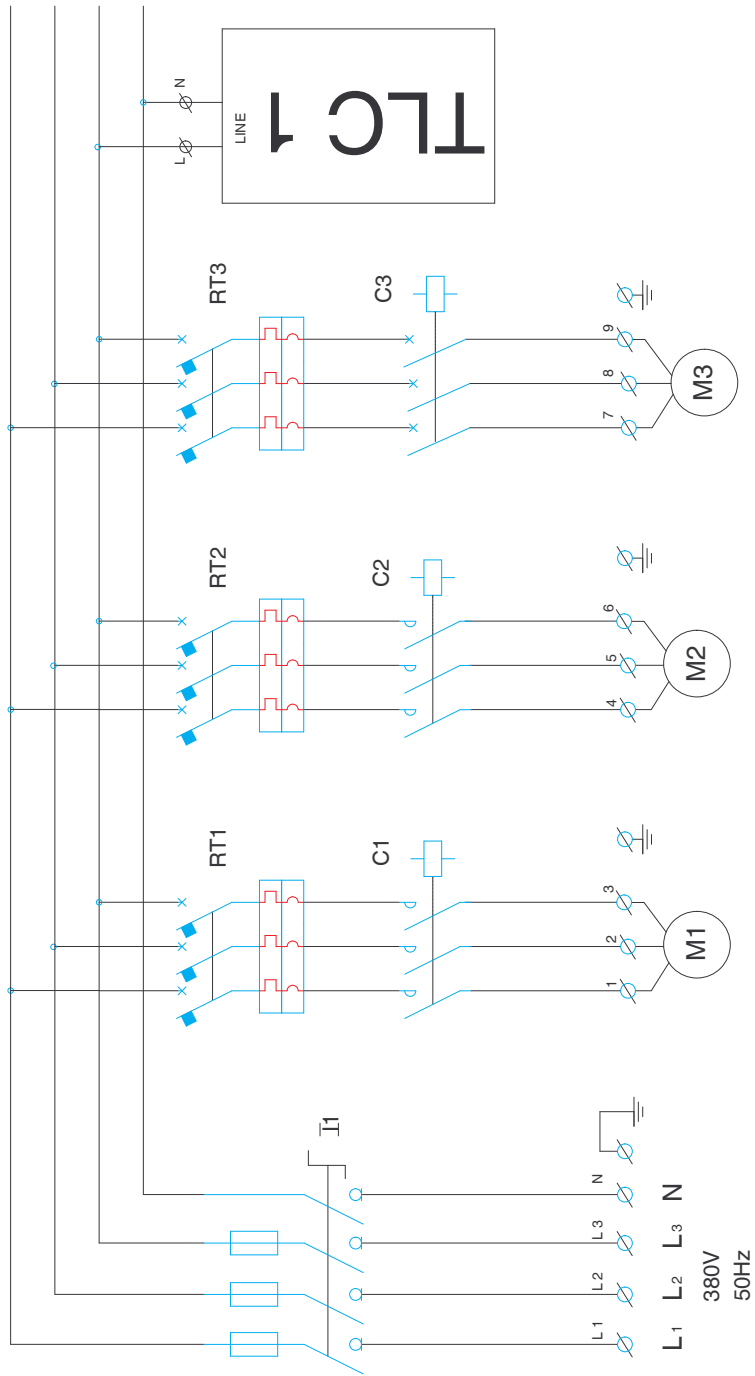

CIRCUIT DESCRIPTION	MAIN SWITCH	VENTILATION FAN 1 MOTOR	VENTILATION FAN 2 MOTOR	SMOKE FAN MOTOR	TLC 1
ACTIVE POWER	5.7	3	1.5	1.1	
APPLIED CURRENT	14	7.2	3.7	2.8	
PHASES	4	3	3	3	
NOMINAL CURRENT		6.3/10	4/6.3	2.5/4	
REGULATED CURRENT		7.6	4	3	
CUT-OFF POWER		50 (BACK-UP WITH FUSES)	100	100	
CONTACTOR		4	4		
SWITCH		400	400		
VALVES		32		400	
		32		16	
		20			

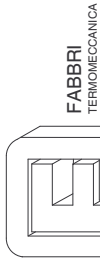

STANDARD
F350

SHEET
2 - 2

DEFINIZIONI

- Ib - Actual applied current (device absorption)
- In - Nominal current
- Ir - Regulated current
- Pn - Nominal active power
- Vn - Nominal voltage (of the appliance)

LEGEND

- I - Distribution switches
- RT - Temperature relays
- T - Thermostat contact
- M - Motors
- C - Contactors

NOTE

- The thermostats marked (T), with contacts indicated by various numbers, either refer to one thermostat with several different intervention thresholds or to individual thermostats (one for each number).
 - The control panel face plate dimensions indicated are intended as a guideline only.
 - The protection class of the control panel and the corresponding connections to individual pieces of furnace equipment must be at least IP44.
 - The main switch handles interlock with the cover. The control panel may only be opened when the switch is in the open position.
- N.B.
- During installation, the Purchaser must protect the hot air generator from "Indirect Contact", in compliance with current CEI standards. We recommend the use of a diff. switch with a 30 mA cut-off threshold, which will protect the main power supply line.

TLC 1 CONNECTIONS

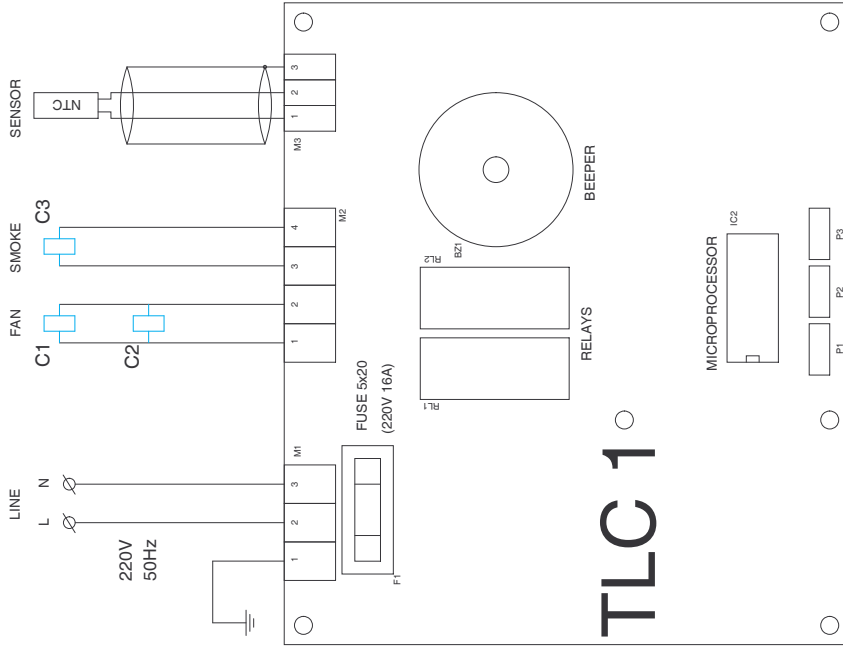

TLC 1

CONTROL PANEL FACE PLATE

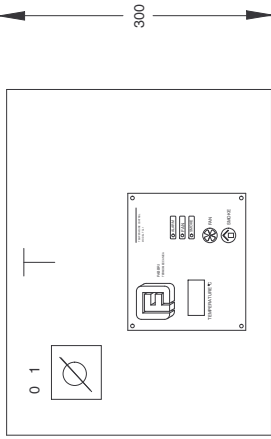

TERMINAL BOARD

